

ALL RIGHTS RESERVED. REPRODUCTION OR ISSUE TO THIRD PARTIES IN ANY FORM WHATSOEVER IS NOT PERMITTED WITHOUT WRITTEN AUTHORITY FROM THE PROPRIETORS.

HER HAKKI MAHFUZDUR. YAZILI IZIN OLMADAN DOKÜMANLARIN HIÇ BİR KISMI KOPYA, KAYIT, BASIM VEYA DİĞER HERHANGİ BİR ŞEKİLDE ÇOĞALTILMAZ VE YAYINLANMAZ.

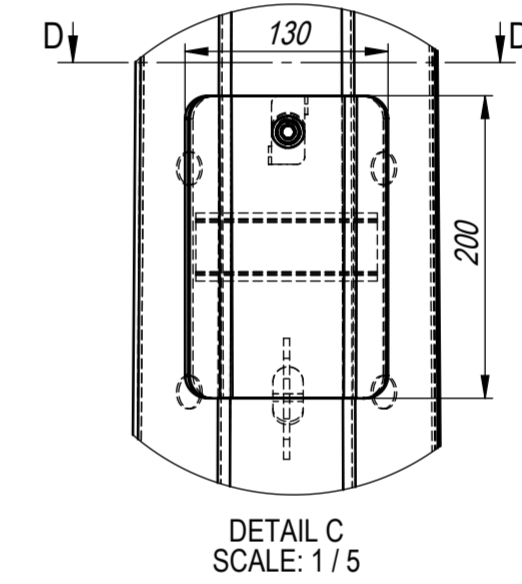
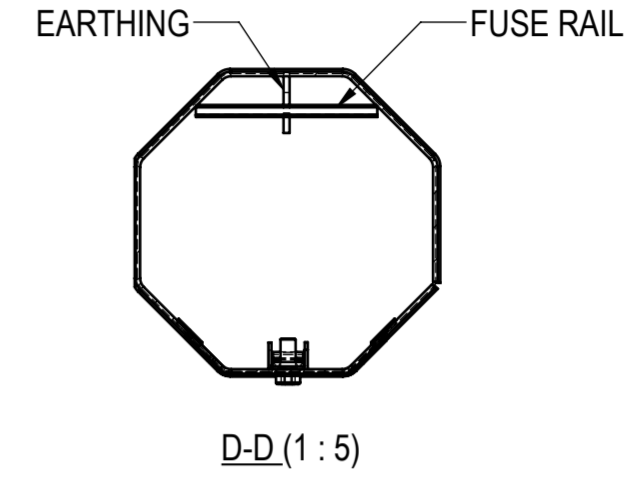
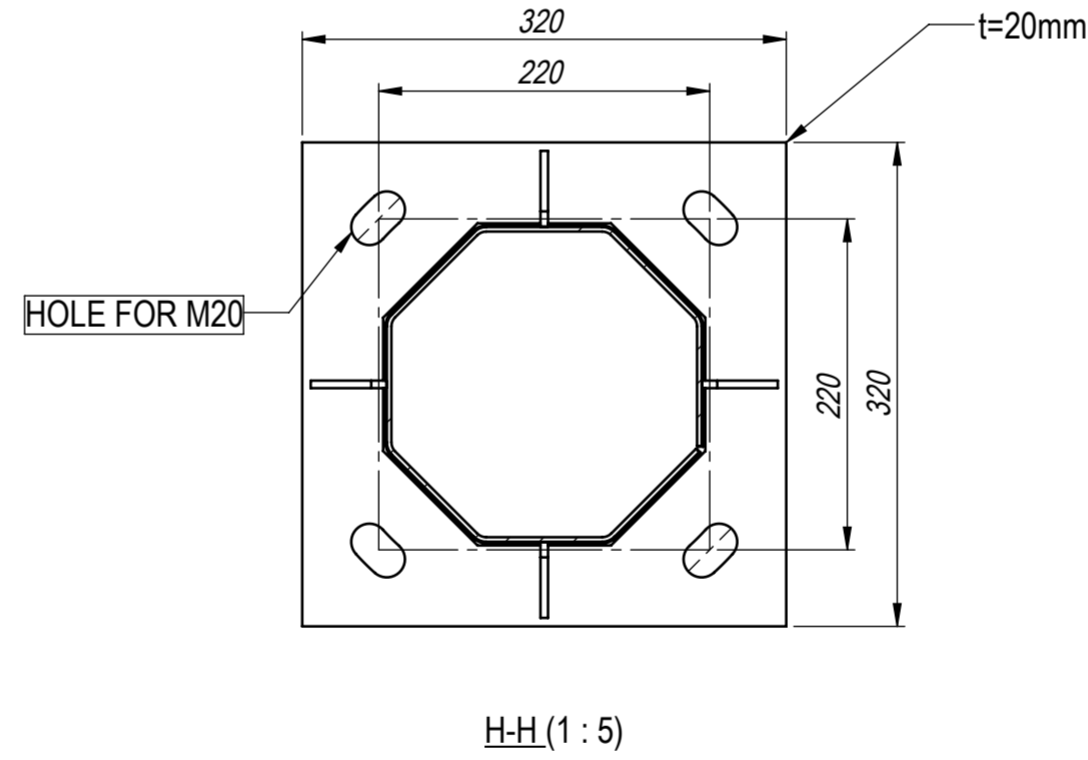
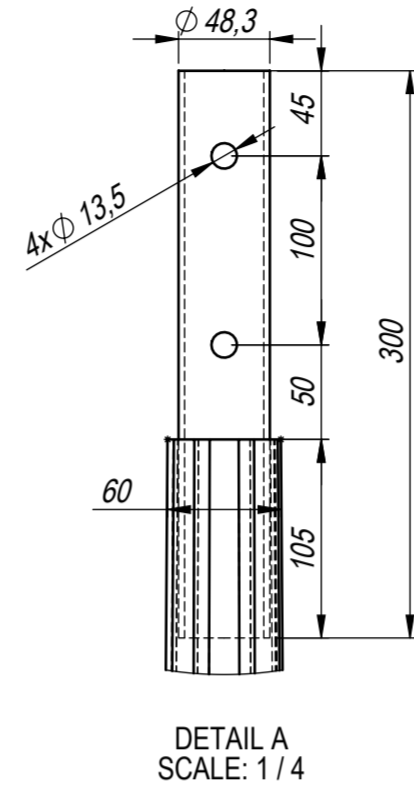
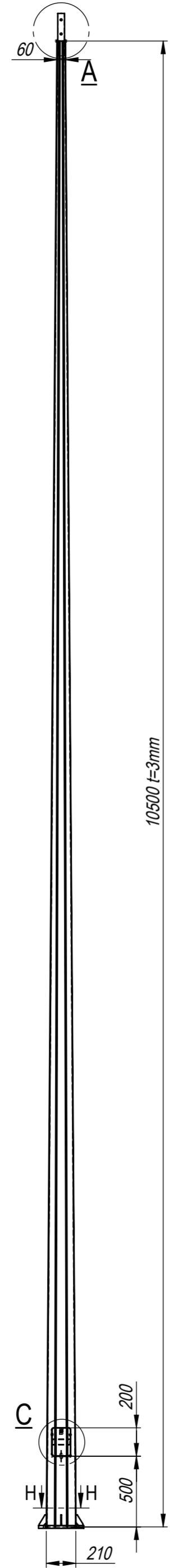
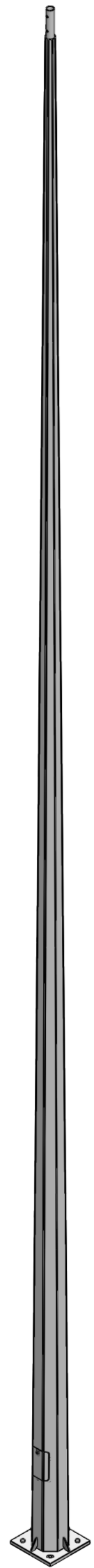

ANCHOR SET: AC SET 4

REVİZYONLAR / REVISIONS					
REV.	TANIM DESCRIPTION	TARİH DATE	İMZA SIGN	ONAY APPROVED	
GENEL NOTLAR GENERAL NOTES					
TÜM ÖLÇÜLER mm'DİR. ALL DIMENSIONS ARE IN mm.					
TÜM ÇELİK ELEMANLAR, CIVATA, SOMUN VE RONDALALAR SICAK DALDIRMA GALVANİZDİR. (EN ISO 1461)					
ALL STEEL ITEMS, BOLTS, NUTS & WASHERS TO BE HOT-DIP GALV. AS PER (EN ISO 1461)					
TASARIM KRİTERLERİNE GÖRE CIVATALAR (ISO 898) 5.8 & 6.8 & 8.8 OLARAK KULLANILABİLİR. BOLTS CAN BE USED AS (ISO 898) 5.8 & 6.8 & 8.8 ACCORDING TO DESIGN CRITERIA.					
CİZEN DRAWN BY	ADI - SOYADI NAME - SURNAME	TARİH DATE	İMZA SIGN	MALZEME MATERIAL	TASARIM NOTLARI DESIGN NOTES
CİZEN DRAWN BY	NEKAPLAN	17.12.2019		GÖVDE SHAFT	S235 TASARIM RÜZGAR HIZI DESIGN WIND SPEED 130 km/H
KONTROL CONTROL	I.YUCEL	17.12.2019		FLANŞ FLANGE	S235 GÜVENLİK KATSAYISI FACTOR OF SAFETY 1.67
ONAY APPROVAL	K.CANBALOGLU	17.12.2019		DİĞER OTHER	S235 TASARIM STANDARTI DESIGN STANDART
PAD2-110-30 OUTLINE					
SİPTEK. NO ORDER NUMBER	STANDART				
PAFTA NO DRAWING NUMBER	PAD2-110-30				
TARİH DATE	19.12.2019				
AGIRLIK WEIGHT					
BÖLÜM DEPARTMENT	POLİGON	SHEET 1 OF 1	ÖLÇEK SCALE 1:100	A2	REV 0

